

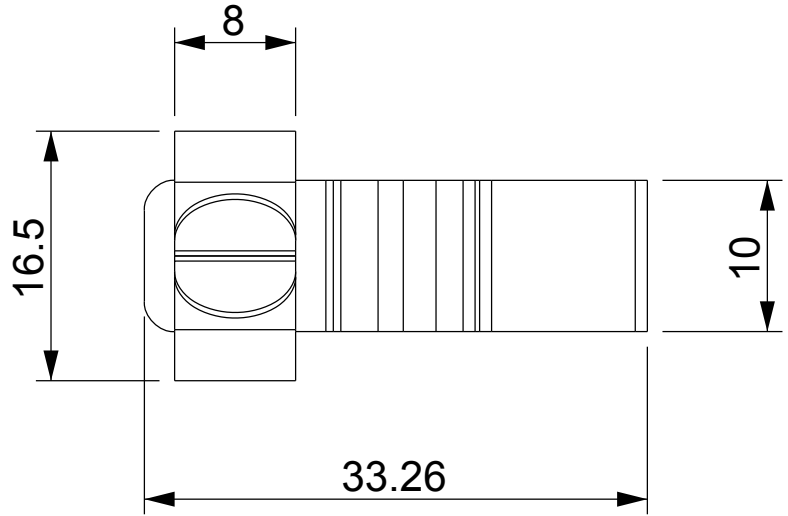

DIM.	TOL.
5mm DOWN	±0.2
5~20mm	±0.3
20~40mm	±0.4
40~60mm	±0.5
60~100mm	±0.8
100mm UP	±1.0

REVISIONS			
REV	DESCRIPTION	DATE	BY

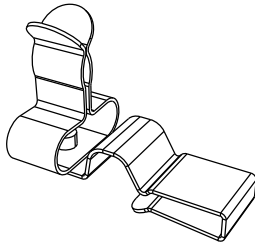
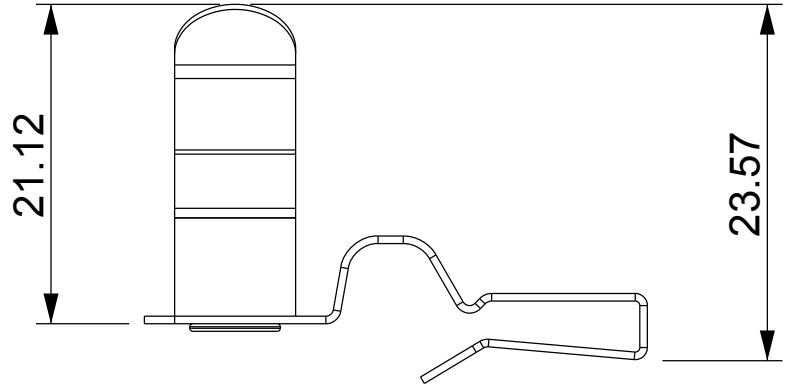
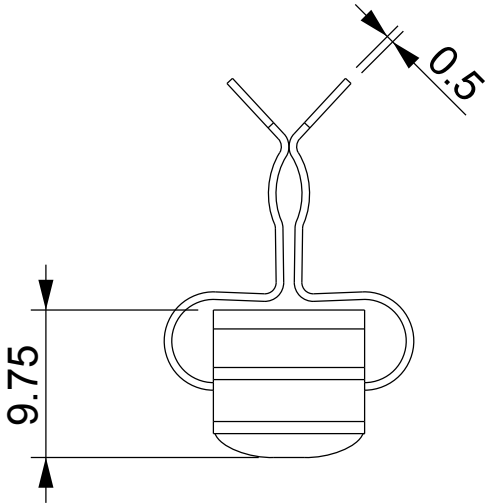

 Size of the cable ties: width max 3.5 mm  
 thickness max 3 mm

**Note:**  
 It is not necessary to pull the cable ties all the way  
 but only until the strain relief effect is guaranteed.

		TITLE <b>SPRING STEEL</b>	
		MATERIAL STEEL ZINC PLATED	DATE 25/03/2024
PART NUMBER 19183MC94		DRAWING NUMBER 24/03/25.19184.E	CHECK A.C.
SIZE A4	SCALE 2:1	UNIT mm.	REV A
UNLESS OTHERWISE SPECIFIED TOLERANCE SEE ABOVE		APPROVED	