

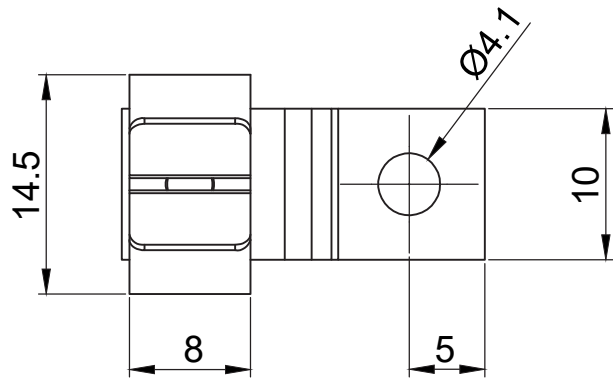

REVISIONS			
REV	DESCRIPTION	DATE	BY

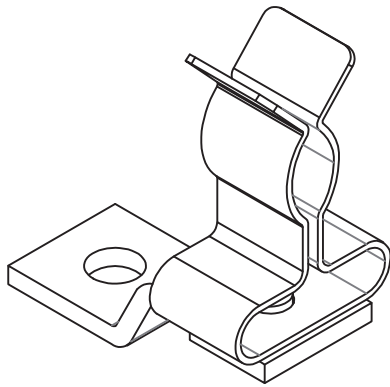
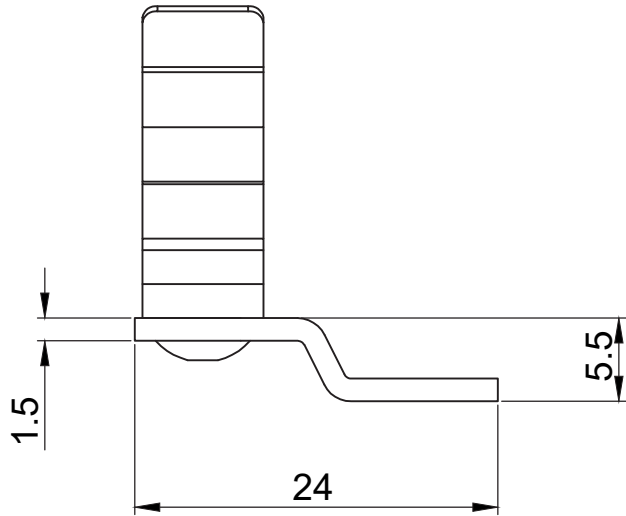
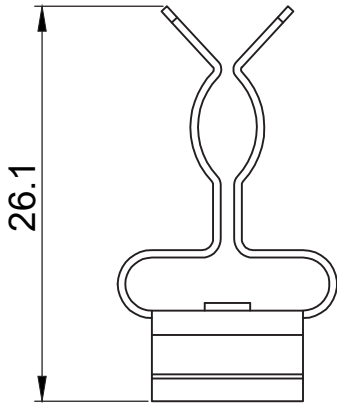

Size of the cable ties: width max 3mm
thickness max 9 mm

		TITLE SHIELD CLAMP	
		MATERIAL STEEL ZINC PLATED	DATE 28/03/2024
PART NUMBER 19155MC94		DRAWN E.B.	
DRAWING NUMBER 24/03/28.19155.E		CHECK	
SIZE A4	SCALE 1:2	COLOR GREY	APPROVED
UNIT mm.	REV A	UNLESS OTHERWISE SPECIFIED TOLERANCE SEE ABOVE	