

REVISIONS			
REV	DESCRIPTION	DATE	BY

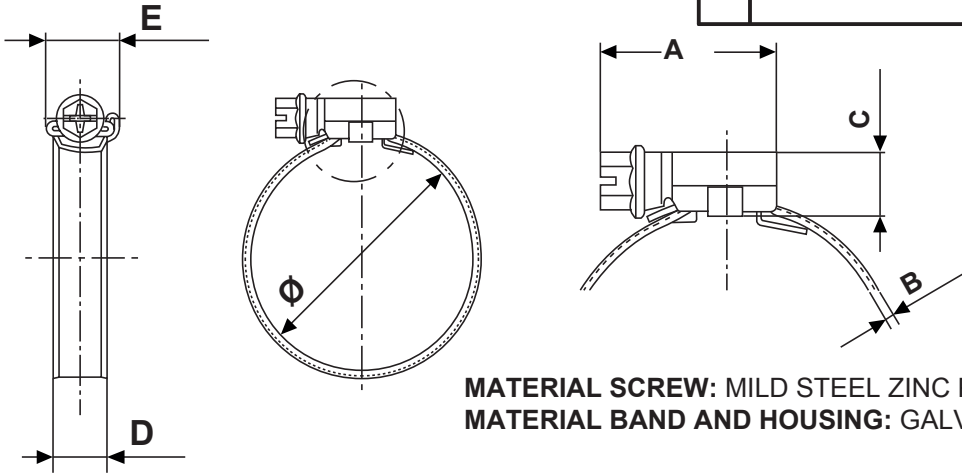

MATERIAL SCREW: MILD STEEL ZINC PLATED
MATERIAL BAND AND HOUSING: GALVANIZED STEEL

P/N	A	B	C	D	E	Ø	VALUES TORQUE (Nm)	MAX. PRESSURE (Bar)
20700MC90	17,5	0,65	8,4	7,0	10,9	8,0-12,0	1,5	30
20701MC90	22,1	0,65	10,5	9,0	14,0	8,0-16,0	3,0	45
20702MC90	22,1	0,65	10,5	9,0	14,0	12,0-22,0	3,0	45
20703MC90	23,6	0,75	10,5	9,0	14,0	16,0-27,0	3,5	42
20704MC90	23,6	0,75	10,5	9,0	14,0	20,0-32,0	3,5	36
20705MC90	25,6	0,75	10,5	9,0	14,0	25,0-40,0	4,0	32
20706MC90	25,6	0,75	10,5	9,0	14,0	30,0-45,0	4,0	28
20707MC90	25,6	0,75	10,5	9,0	14,0	32,0-50,0	4,0	24
20708MC90	25,6	0,75	10,5	9,0	14,0	40,0-60,0	4,0	19
20709MC90	29,6	0,75	10,5	9,0	14,0	50,0-70,0	4,0	17
20710MC90	29,6	0,75	10,5	9,0	14,0	60,0-80,0	4,0	15
20711MC90	29,6	0,75	10,5	9,0	14,0	70,0-90,0	4,0	13
20712MC90	29,6	0,75	10,5	9,0	14,0	80,0-100,0	4,0	11
20713MC90	29,6	0,75	10,5	9,0	14,0	90,0-110,0	4,0	10
20714MC90	29,6	0,75	10,5	9,0	14,0	100,0-120,0	4,0	9
20715MC90	29,6	0,75	10,5	9,0	14,0	110,0-130,0	4,0	8
20716MC90	29,6	0,75	10,5	9,0	14,0	120,0-140,0	4,0	7
20717MC90	29,6	0,75	10,5	9,0	14,0	130,0-150,0	4,0	6
20718MC90	29,6	0,75	10,5	9,0	14,0	140,0-160,0	4,0	5

NOTES:

The maximum application pressure can vary depending on the type of hose used and the geometry of the coupling.

				TITLE HOSE CLAMP "L" WORM DRIVE CLIP W1	
				MATERIAL SEE ABOVE	
PART NUMBER SEE ABOVE				DRAWING NUMBER 22.05.24.207XX.0.E	
FINISH				CHECK	
SIZE A4	SCALE NTS	UNIT mm.	REV A	UNLESS OTHERWISE SPECIFIED TOLERANCE SEE ABOVE	
				APPROVED	