

REVISIONS			
REV	DESCRIPTION	DATE	BY

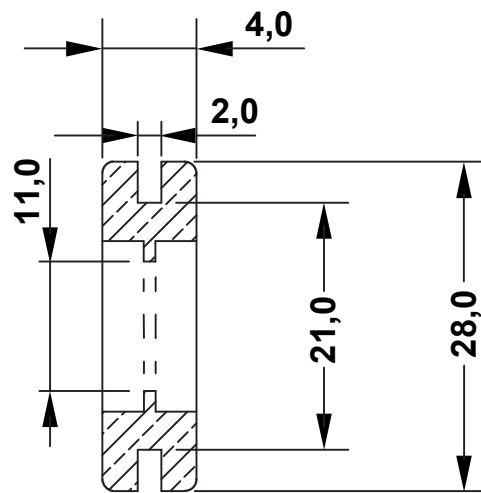

SECTION A-A

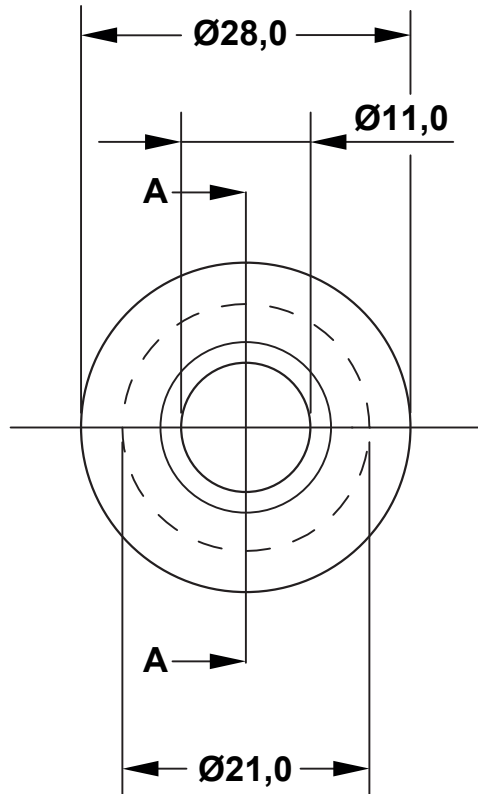

TITLE		GROMMET WITH PERFORATED MEMBRANE	
MATERIAL		DATE	30/08/2019
PVC 50 SH		DRAWN	R.F.
COLOR		CHECK	
BLACK		APPROVED	
UNLESS OTHERWISE SPECIFIED TOLERANCE			

PART NUMBER		DRAWING NUMBER	
12090CA01M		19.08.30.12090.0.E	
SIZE	SCALE	UNIT	REV
A4	NTS	mm.	A