

DIM.	TOL.
5mm DOWN	±0.2
5~20mm	±0.3
20~40mm	±0.4
40~60mm	±0.5
60~100mm	±0.8
100mm UP	±1.0

REVISIONS			
REV	DESCRIPTION	DATE	BY

BODY

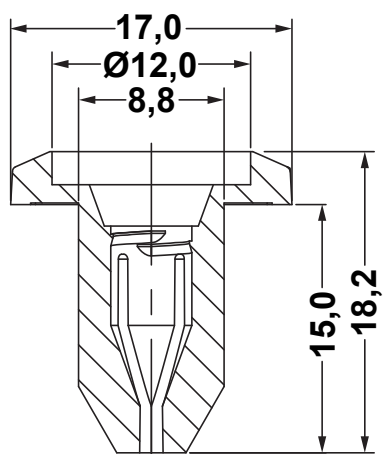

PIN

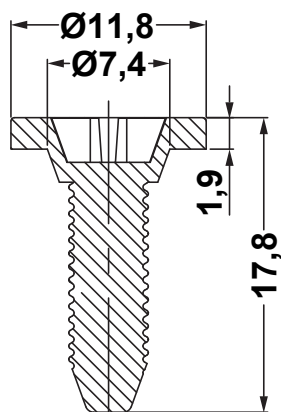

ASSEMBLY PART

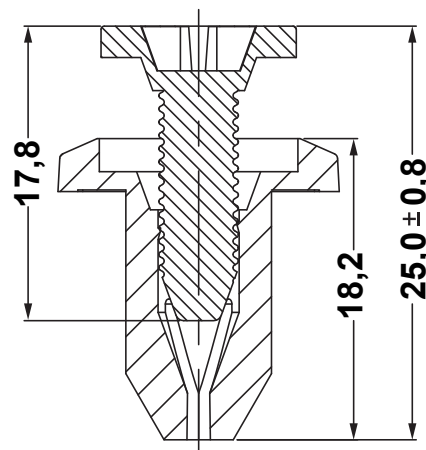

**MOUNTING HOLE \square 9,0 X 9,0
PANEL THICKNESS 6,7 mm**



TITLE		SCREW RIVETS	
MATERIAL		DATE	15/04/2019
PVC		DRAWN	R.F.
COLOR		CHECK	
BLACK		APPROVED	
UNLESS OTHERWISE SPECIFIED TOLERANCE		SEE ABOVE	

PART NUMBER		DRAWING NUMBER	
12937AA01		19.04.15.12937.0.E	
SIZE	SCALE	UNIT	REV
A4	NTS	mm.	A