

DIM.	TOL.
5mm DOWN	±0.2
5~20mm	±0.3
20~40mm	±0.4
40~60mm	±0.5
60~100mm	±0.8
100mm UP	±1.0

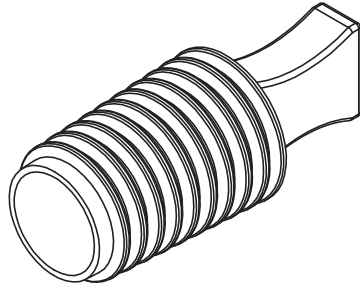

REVISIONS			
REV	DESCRIPTION	DATE	BY

SECTION Y-Y

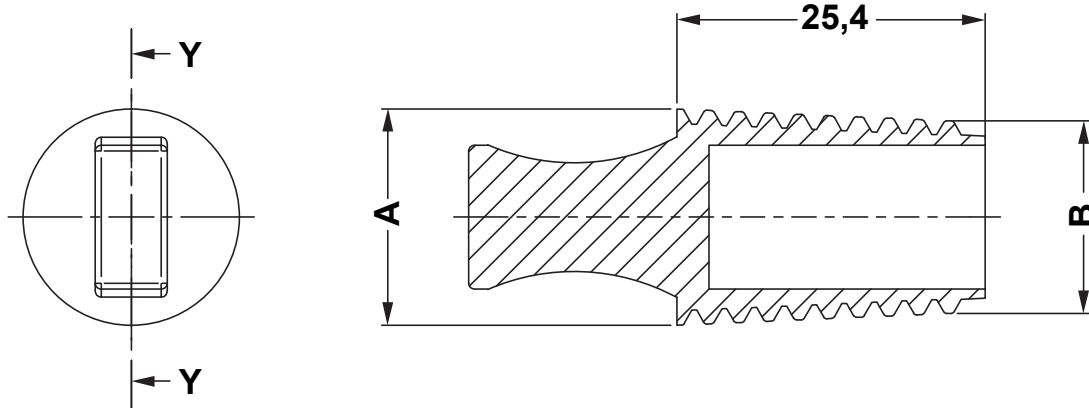

P/N	A	B
25098SI00	6,0	4,0
25099SI00	8,0	6,0
25100SI00	10,0	8,0
25101SI00	12,0	10,0
25102SI00	14,0	12,0
25103SI00	16,0	14,0
25104SI00	18,0	16,0

P/N	A	B
25105SI00	20,0	18,0
25106SI00	22,5	20,0
25107SI00	24,0	22,5
25108SI00	26,0	24,0
25109SI00	28,0	26,0
25110SI00	28,6	25,4
25111SI00	31,8	28,6

NOTES:

For high temperatures: resistant up to 315 ° C

				TITLE HIGH TEMPERATURE FLANGELESS PLUGS	
				MATERIAL SILICONE RUBBER	
PART NUMBER SEE TABLE				DRAWN R.F.	
DRAWING NUMBER 18.05.16.25XXX.0.E				CHECK	
COLOUR NATURAL				APPROVED	
SIZE A4	SCALE NTS	UNIT mm.	REV A	UNLESS OTHERWISE SPECIFIED TOLERANCE SEE ABOVE	