

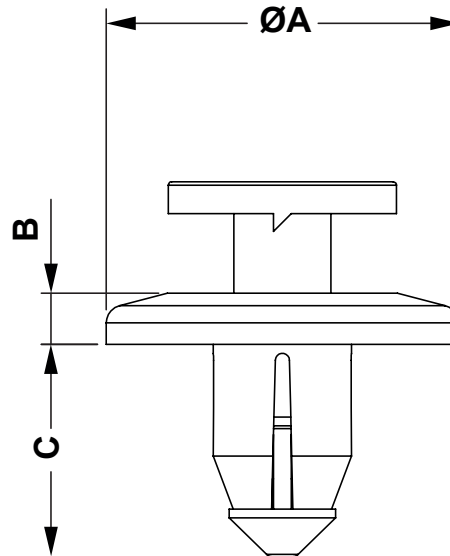

DIM.	TOL.
5mm DOWN	±0.2
5~20mm	±0.3
20~40mm	±0.4
40~60mm	±0.5
60~100mm	±0.8
100mm UP	±1.0

REVISIONS			
REV	DESCRIPTION	DATE	BY



P/N	A	B	C	HOLE	THICKNESS
8095GA01	17,9	2,3	16,2	Ø 6,0	3,0 - 5,0
8096GA01	16,0	2,3	14,2	Ø 7,0	2,5 - 5,0
8097GA01	19,9	2,9	18,3	Ø 8,0	3,5 - 6,0
8098GA01	18,7	3,6	25,4	Ø 9,0	4,0 - 7,5

				TITLE QUARTER TURN RIVET	
				MATERIAL POM HB(UL94)	
PART NUMBER SEE TABLE				DRAWING NUMBER 20.03.03.809X.0.E	
SIZE A4		SCALE NTS		COLOR BLACK	
UNIT mm.		REV A		CHECK	
UNLESS OTHERWISE SPECIFIED TOLERANCE SEE ABOVE				APPROVED	