

## PASSACAVI CON MEMBRANA



### Descrizione tecnica

#### Materiale:

- TPE Shore A 45
- PVC Shore 50

**Colore:** Nero

**Autoestinguenza:** HB (UL94)

#### Temperatura esercizio:

- **TPE:** -28°C ~ +90°C
- **PVC:** -25°C ~ +60°C

Tutte le quote sono in mm.

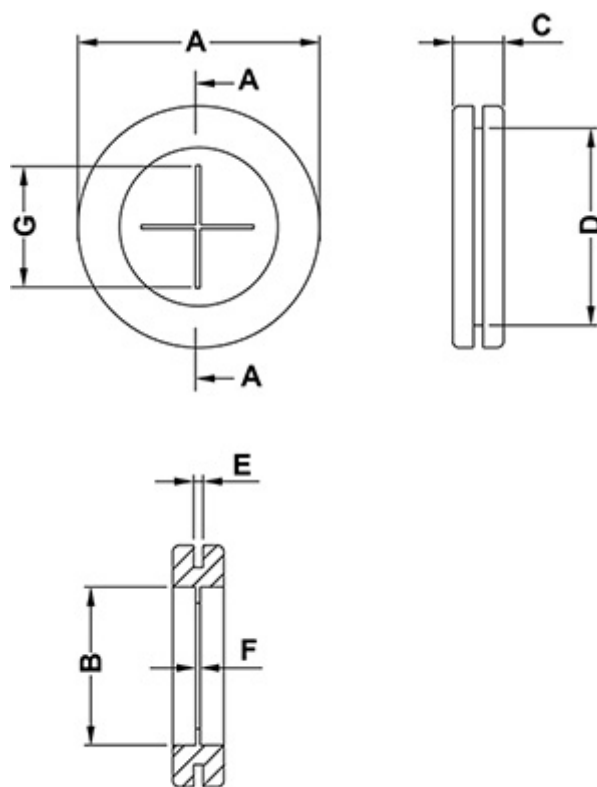

**SECTION A-A**

Codice	A	B	C	D	E	F	G	Materiale	Conf./pezzi
5853PF01MS	20,0	9,0	7,0	15,5	2,0	1,0	6,0	TPE Shore A 45	1.000
5854PF01MS	23,0	11,0	7,0	18,5	2,0	1,0	10,0	TPE Shore A 45	1.000
14878PD01M	25,4	16,0	7,1	19,1	2,0	-	-	Rubber (NR)	1.000
5855PF01MS	25,0	13,5	7,0	20,5	2,0	1,0	10,0	TPE Shore A 45	1.000
5856PF01MS	27,5	16,0	7,0	22,5	2,0	1,0	10,0	TPE Shore A 45	1.000
13170CA01MS	33,8	21,0	7,4	26,0	2,0	1,0	21,0	PVC Shore 50	1.000
14977CA01M	35,0	22,0	8,0	27,0	2,0	1,0	-	PVC Shore 70	1.000
5857PF01MS	35,0	21,0	8,0	28,0	2,0	1,0	14,0	TPE Shore A 45	1.000
5858PF01MS	44,0	29,0	9,0	37,0	2,0	1,0	17,0	TPE Shore A 45	1.000
5859PF01MS	54,0	36,0	10,0	47,0	2,5	1,2	27,0	TPE Shore A 45	500
5876PF01MS	68,0	47,0	9,0	59,0	2,5	1,5	27,0	TPE Shore A 45	250