

MOLLETTE DI SCHERMATURA PER GUIDA DIN/OMEGA



Descrizione tecnica

Materiale: Acciaio per molle

Tutte le quote sono in mm



TYPE 1

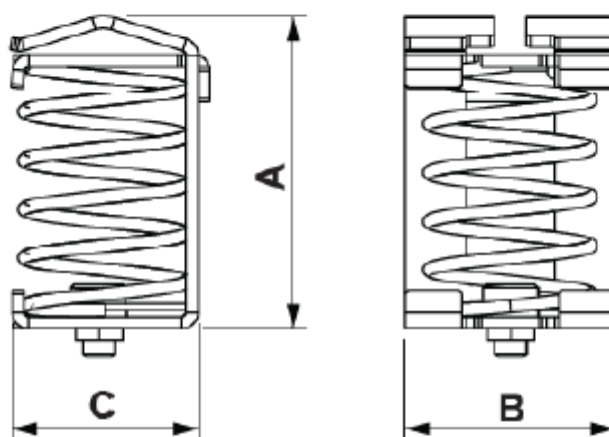

TYPE 2

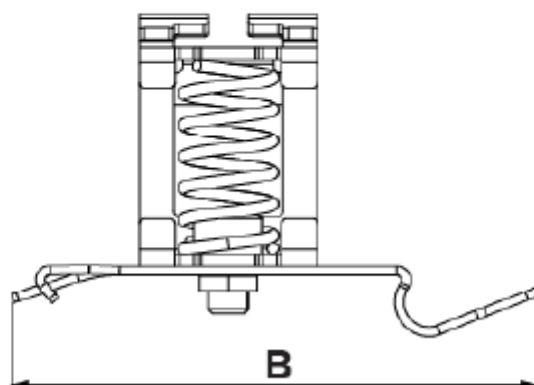

Codice	Type	A	B	C	Ø Diametro cavo	Conf./pezzi
19143MC94	2	26,0	50,0	14,5	Ø 3,0 - 8,0	10
19144MC94	1	30,0	18,0	15,0	Ø 4,0 - 13,5	10
19145MC94	2	30,0	50,5	20,5	Ø 4,0 - 13,5	10
19146MC94	1	40,0	26,0	25,0	Ø 10,0 - 20,0	10
19147MC94	2	40,0	50,5	25,5	Ø 10,0 - 20,0	10
19148MC94	1	64,0	32,0	36,0	Ø 15,0 - 32,0	10

Codice	Type	A	B	C	Ø Diametro cavo	Conf./pezzi
19149MC94	2	64,0	50,5	34,5	Ø 15,0 - 32,0	10