

SOPORTE PARA CIRCUITO IMPRESO

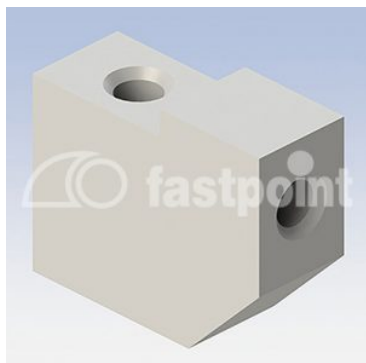

Descripción Técnica

Material: PA66

Color: Natural

Autoextinguibilidad: UL94-V2

Temperatura de trabajo: -35°C ~ +85°C

Todas las medidas están indicadas en mm

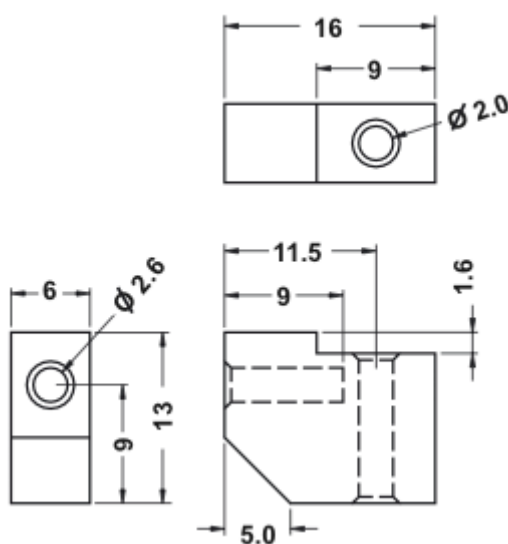

Codigo	A	B	C	D	E	F	G	H	I	J	K	Autoextinguible	Conf./piezas
6113AA00	16,0	9,0	11,5	9,0	1,6	5,0	6,0	13,0	9,0	Ø2,0	Ø2,6	V2 (UL94)	500
6113AR00	16,0	9,0	11,5	9,0	1,6	5,0	6,0	13,0	9,0	Ø2,0	Ø2,6	V0 (UL94)	500