

# CLIPS



## Descrizione Técnica

**Material:** PA66 o POM ( ver tabla )

**Color:** Natural o negro ( ver tabla )

### Autoextinguibilidad:

- PA66: UL94-V2
- POM: UL94-HB

### Temperatura de trabajo:

- PA66: -35°C ~ +85°C
- POM: -40°C ~ +85°C

Todas las medidas están indicadas en mm

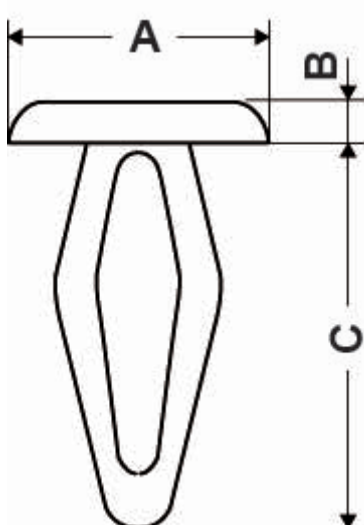

Codigo	A	B	C	Orificio	Espesor	Color	Material	Conf./piezas
0293AA00	6,0	1,2	10,0	Ø 3,0	0,5 - 3,5	Naturale o negro	PA 6.6	2.500
12215GA00	12,0	2,0	16,8	Ø 6,4	1,5 - 6,5	Naturale	POM	2.000

Codigo	A	B	C	Orificio	Espesor	Color	Material	Conf./piezas
12275AA00	4,8	0,9	6,5	Ø 2,5	2,0 - 2,5	Naturale	PA 6.6	1.000
12276AA00	6,3	0,8	6,5	Ø 2,5	2,0 - 2,5	Naturale	PA 6.6	2.000
12276AA02	6,3	0,8	6,5	Ø 2,5	2,0 - 2,5	Bianco	PA 6.6	2.000
5394AA00	6,5	1,2	10,0	Ø 3,0- 3,5	0,5 - 3,5	Naturale o nero	PA 6.6	5.000
5452AA00	7,3	1,7	10,2	Ø 3,2-3,5	1,0 - 2,5	Naturale o nero	PA 6.6	2.500
6046GA00	8,0	1,5	13,0	Ø 3,2	1,0 - 4,5	Naturale	POM	2.000
6726GA00	9,0	1,6	14,0	Ø 3,9	1,0 - 5,0	Naturale	POM	1.000
8494AR00	11,0	2,9	15,0	Ø 4,7	1,0 - 5,5	Naturale	PA 6.6	2.000