

ARANDELAS ATORNILLABLES

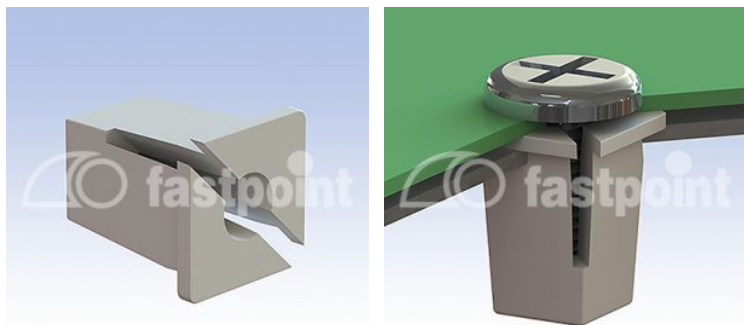

Descripción Técnica

Material: PA66

Color: Natural

Autoextinguibilidad: UL94-V2

Temperatura de trabajo: -35°C ~ +85°C

Todas las medidas están indicadas en mm

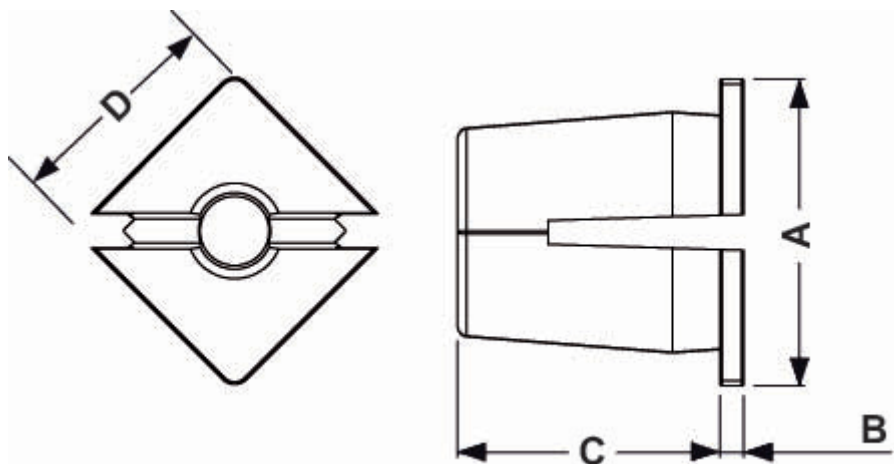

Codigo	A	B	C	D	Orificio	Espesor	Tornillo	Conf./piezas
0093AA00	12,2	1,0	11,0	9,2 x 9,2	7,0 x 7,0	0,5 - 2,0	0,8	2.500
0098AA00	12,2	1,0	11,0	9,2 x 9,2	7,0 x 7,0	0,5 - 2,0	0,8	2.500
0101AA00	15,0	1,2	18,0	12,2 x 12,2	9,5 x 9,5	0,5 - 2,0	8 -10 P	2.500
3515AA00	12,8	0,8	11,5	11,0 x 11,0	8,0 x 8,0	0,7 - 2,0	0,9	2.500