

ARANDELAS ATORNILLABLES

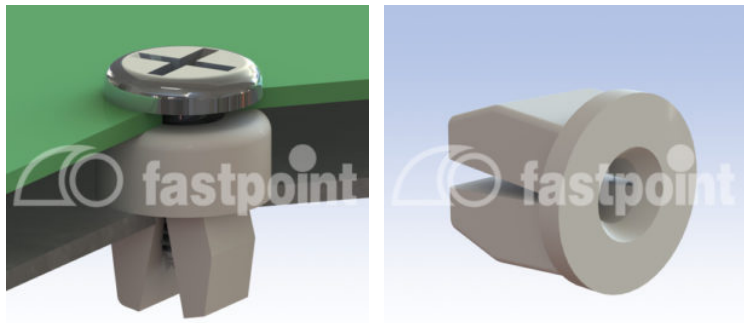

Descripción Técnica

Material: PA66

Color: Natural

Autoextinguibilidad: UL94-V2

Temperatura de trabajo: -35°C ~ +85°C

Todas las medidas están indicadas en mm

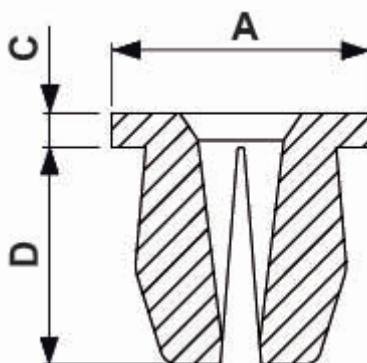

Codigo	A	C	D	Orificio	Tornillo	Conf./piezas
0108AA00	Ø 8,5	1,2	5,5	4,5x4,5	6P	2.500
0115AA00	Ø 9,5	1,3	8,0	7,0x7,0	8 P	2.500
0116AA00	Ø 13,0	1,0	8,0	7,0x7,0	8 - 10 P	2.500