

ARANDELA DE ACABADO



Descripción Técnica

Material: PA66

Color: Negro

Autoestinguibilidad: UL94-V2

Temperatura de trabajo: -35°C ~ + 85°C

Todas las medidas están indicadas en mm

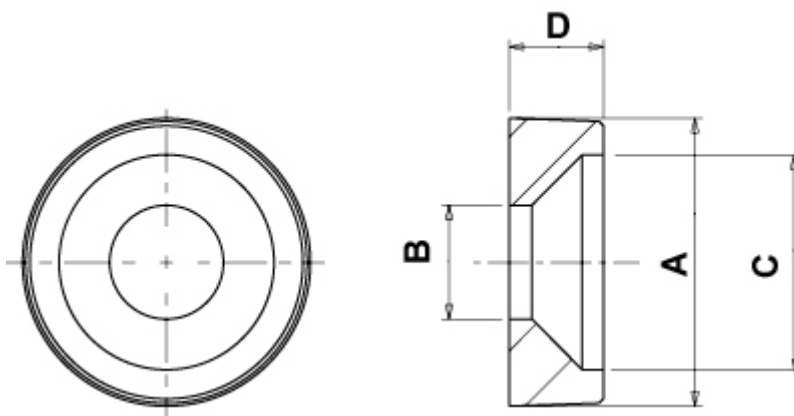

Codigo	A	B	C	D	Passo	Conf./piezas
2897AA01	8,0	3,0	6,0	2,6	M3	1.000
2898AA01	10,7	4,0	8,0	3,5	M4	1.000
2899AA01	13,4	5,0	10,0	4,4	M5	1.000
2900AA01	16,0	6,0	12,0	5,2	M6	1.000
2901AA01	21,4	8,0	16,0	7,0	M8	1.000