

SHIELD CLAMPS FOR 10 X 3 MM BAR



Technical description

Material: Spring steel

All dimensions are in mm

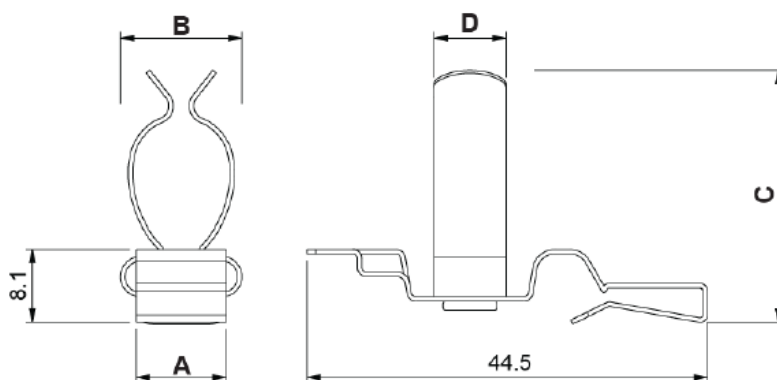

| Code | A | B | C | D | Ø cable diameter | MOQ-Pcs |
|-----------|------|------|------|------|------------------|---------|
| 16403MC94 | 8,0 | 11,0 | 12,0 | 8,0 | Ø1,5 - 3,0 | 50 |
| 16404MC94 | 8,0 | 11,0 | 14,0 | 8,0 | Ø3,0 - 6,0 | 50 |
| 16405MC94 | 8,0 | 11,0 | 17,0 | 8,0 | Ø6,0 - 8,0 | 50 |
| 16406MC94 | 8,0 | 12,0 | 19,0 | 8,0 | Ø8,0 - 11,0 | 50 |
| 16407MC94 | 8,0 | 13,5 | 25,0 | 8,0 | Ø11,0 - 17,0 | 50 |
| 19172MC94 | 10,0 | 22,0 | 37,0 | 8,0 | Ø 18,0 - 22,0 | 50 |
| 19173MC94 | 10,0 | 22,5 | 46,5 | 12,0 | Ø 22,0 - 30,0 | 50 |
| 19174MC94 | 10,0 | 16,5 | 23,5 | 8,0 | Ø 3,0 - 9,0 | 50 |

| Code | A | B | C | D | Ø cable diameter | MOQ-Pcs |
|-----------|------|------|------|-----|------------------|---------|
| 19175MC94 | 10,0 | 19,5 | 30,0 | 8,0 | Ø 10,0 - 19,0 | 50 |