

REVERSE LOCKING P.C.B. SPACERS



Technical description

Material: PA 6.6

Colour:

- Type 1: natural
- Type 2: black

Flammability:

V2 (UL94)

Working temperature:

-35°C ~ +85°C

PA 6.6 V0(UL94) available by special request

All dimensions are in mm

Top and bottom hole:

see table

Panel thickness:

see table

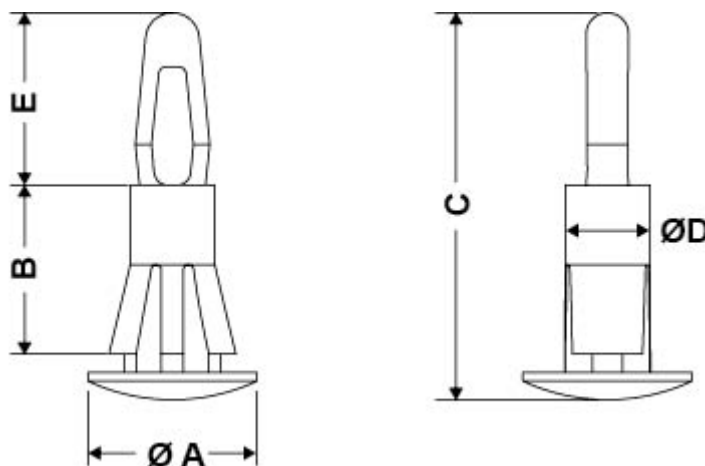

Code	A	B	C	D	E	Top Hole	Top thickness	Bottom hole	Bottom thickness	Flammability	MOQ-Pcs
12020AA0004.8	10,0	4,8	17,7	5,0	10,2	Ø 4,0	1,6	Ø 5,5	1,0 - 1,7	V2 (UL94)	1.000
12020AA0010.0	10,0	10,0	22,9	5,0	10,2	Ø 4,0	1,6	Ø 5,5	1,0 - 1,7	V2 (UL94)	1.000

Code	A	B	C	D	E	Top Hole	Top thickness	Bottom hole	Bottom thickness	Flammability	MOQ-Pcs
9211AR00	V0 (UL94)										