

# INSULATOR SPACER F/F M3 E M4 POLYSTIROL/STEEL



## Technical description

**Material:** Polystyrol

**Thread insert:** Steel zinc plated

**Colour:** grey

**UL flammability:** HB (UL 94)

**Working temperature:** -15°C ~ + 90°C

**Dielectric strength:** 50kV

All dimension are in mm.

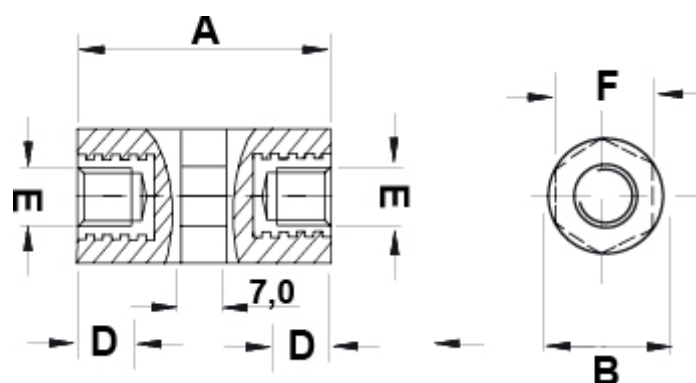

Code	A	B	C	D	E	F	Type	MOQ-Pcs
10483DA1125.0	25,0	7,0	-	7,0	M3	6,0	3	100
10483DA1130.0	30,0	7,0	-	7,0	M3	6,0	3	100
10483DA1140.0	40,0	7,0	-	7,0	M3	6,0	3	100
10486DA1115.0	15,0	10,0	-	7,0	M4	9,0	3	100
10486DA1120.0	20,0	10,0	-	7,0	M4	9,0	3	100
10486DA1125.0	25,0	10,0	-	7,0	M4	9,0	3	100

Code	A	B	C	D	E	F	Type	MOQ-Pcs
10486DA1130.0	30,0	10,0	-	7,0	M4	9,0	3	100
10486DA1140.0	40,0	10,0	-	7,0	M4	9,0	3	100
10486DA1150.0	50,0	10,0	-	7,0	M4	9,0	3	100