

## FIXING PUSH IN CLIP

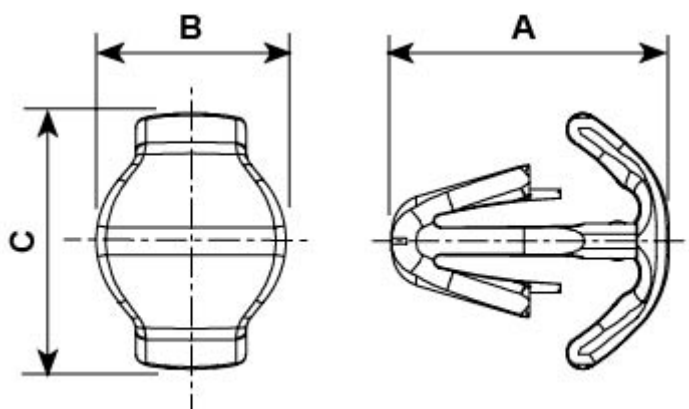

### Technical description



Code	A	B	C	Thickness	Mounting hole	MOQ-Pcs
14577AR02	8,0	5,5	8,0	1,4 - 2,4	Ø 3,0	1.000
14578AR02	9,1	5,5	8,0	2,5 - 3,5	Ø 3,0	1.000
14579AR02	8,0	5,5	8,0	1,4 - 2,4	Ø 4,0	1.000
14580AR02	9,1	5,5	8,0	2,5 - 3,5	Ø 4,0	1.000
14581AR02	8,0	5,5	8,0	1,4 - 2,4	Ø 4,7	1.000
14582AR02	9,1	5,5	8,0	2,5 - 3,5	Ø 4,7	1.000