

FEET AND PUSH-IN BUMPERS



Technical description

Colour: Black

Material: See table

Working temperature:

EPDM: -40°C ~ +130°C

SILICONE: -60°C ~ +250°C

NR: -50°C ~ +80°C

All dimensions are in mm.

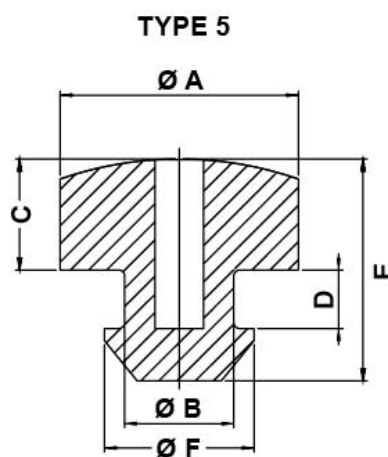
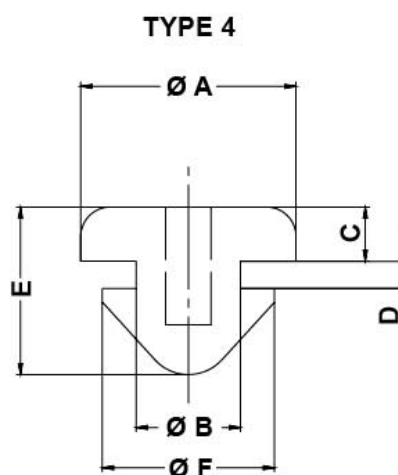
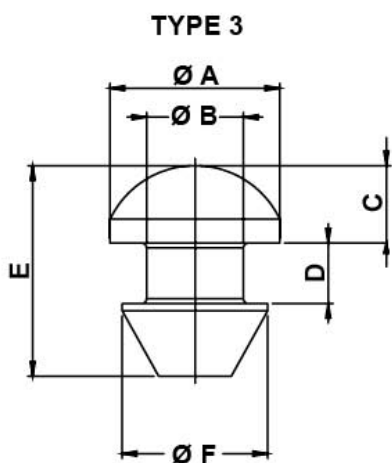
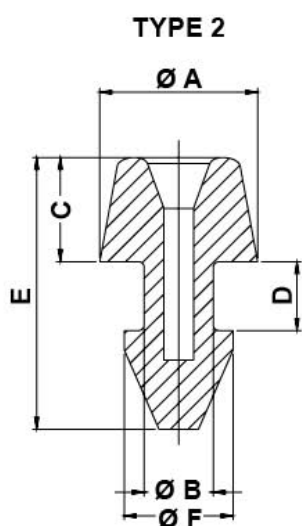
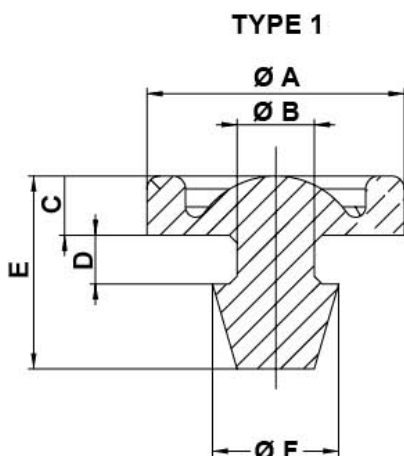

Code	A	B	C	D	E	F	Material	Type	MOQ-Pcs
11248GS01	10,0	3,0	2,3	1,9	7,5	4,9	EPDM 63 Shore A	1	2.500
11249GS01	8,0	3,5	5,5	3,5	14,0	5,5	EPDM 60 Shore A	2	2.500

Code	A	B	C	D	E	F	Material	Type	MOQ-Pcs
11250GS01	7,0	4,0	3,2	2,5	8,7	6,0	EPDM 40 Shore A	3	3.000
11251GS01	9,5	4,6	2,4	1,2	7,4	7,6	EPDM 50 Shore A	4	5.000
11252SI01	11,8	5,4	5,5	2,9	10,9	7,4	SILICONE 50 Shore A	5	3.000
8189PD01	8,0	4,0	2,5	1,7	7,2	6,0	NR 50 Shore A	4	1.000