

# ANGULAR DOUBLE CLIP



## Technical description

**Material:** Hardened steel nickel plated

**All dimensions are in mm**

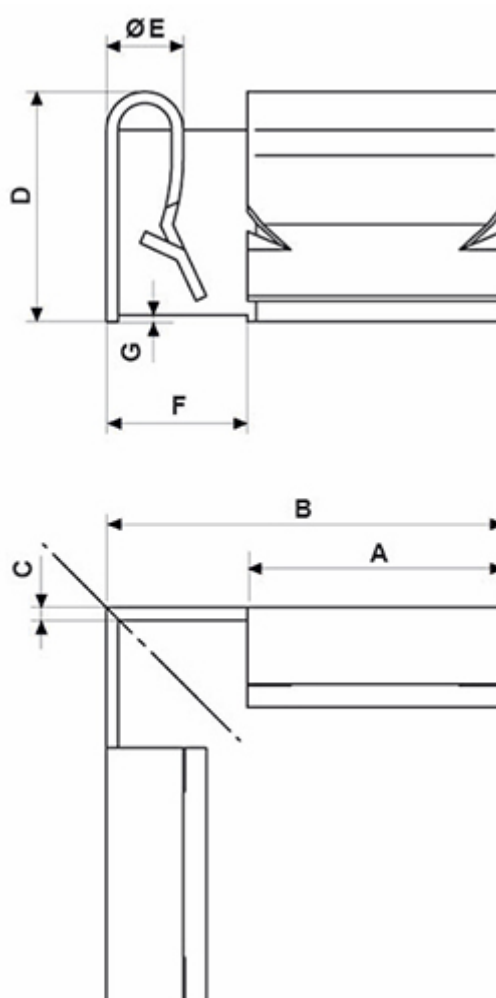

Code	A	B	C	D	E	F	G	MOQ-Pcs
12006MC92	10,0	15,5	0,5	8,0	3,0	5,5	0,25	1.000