

# VORKONFIGURIERTE MODULFLANSCH E IP 65

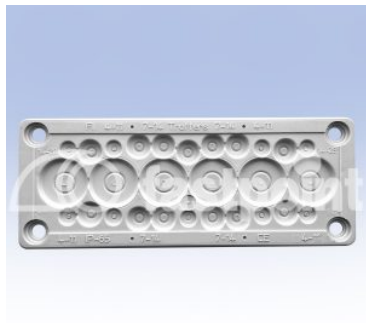

## Technische Beschreibung

**Material:** TPE - SEBS SHORE A50

**Schutzklasse:** IP65

**Betriebstemperatur:** -40°C ~ +130°C

**Farbe:** Grau (RAL 7035)

**Anzahl und ø-Kabel:**

- 18 x ø 6,0 - 13,0

- 6 x ø 13,0 - 28,0

- 4 x ø 3,0 - 11,0

Alle Maße in mm

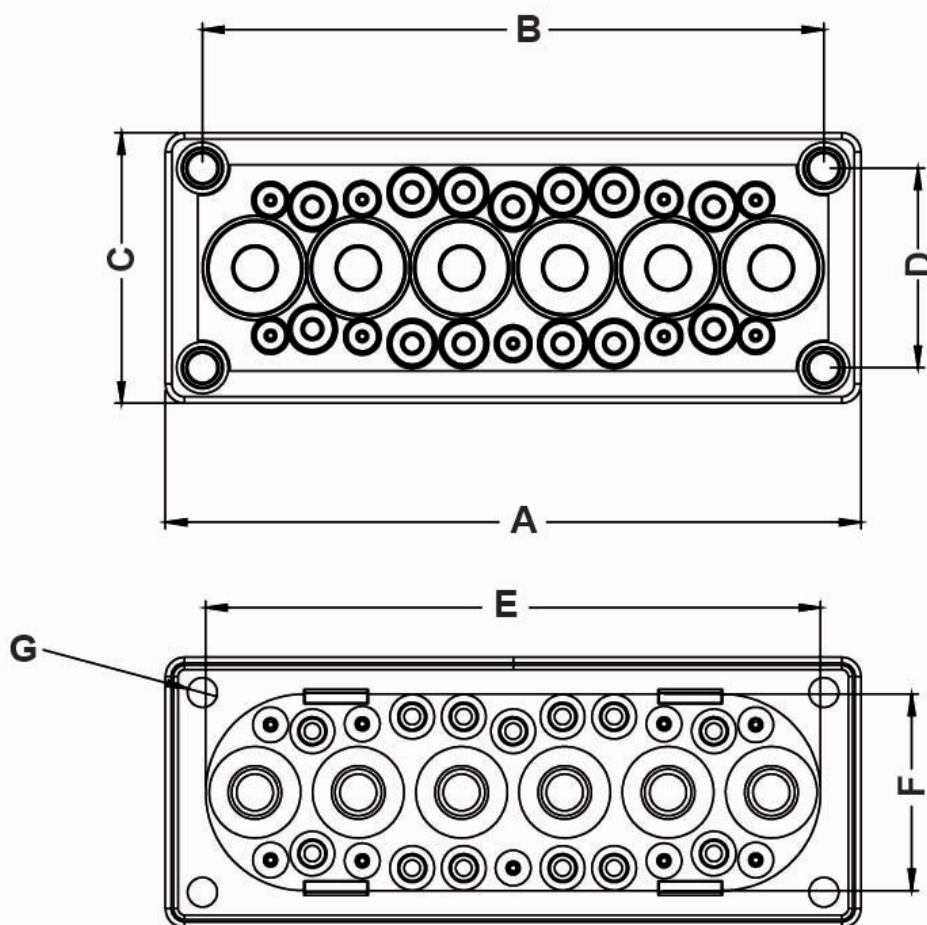

Artikel	A	B	C	D	E	F	G	ANZ. BOHRUNGEN Ø KABEL	VPE-Stckz.
12100PF117035	216,0	193,0	84,0	62,0	191,0	61,0	Ø 9,2	18x6mm - 13mm	100