

# SPREIZMUTTER

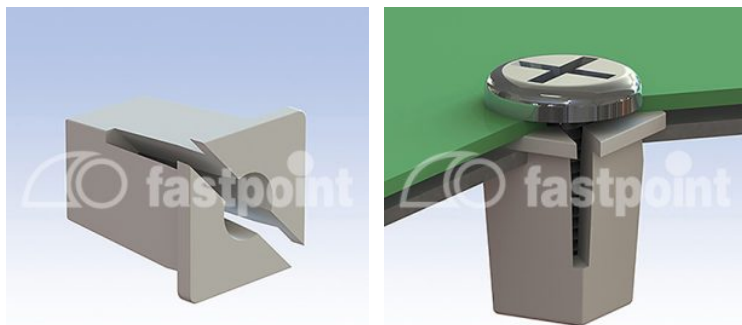

## Technische Beschreibung

**Material:** PA 6.6

**Entflammbarkeit:** V2 (UL 94)

**Temperaturbereich:** -35°C bis +85°C

**Farbe:** Natur oder Schwarz

Alle Maße in mm

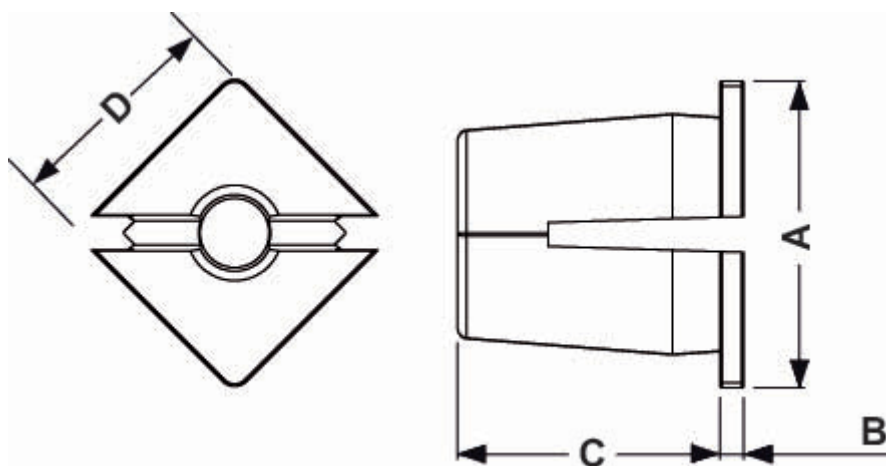

Artikel	A	B	C	D	Bohrung	Stärke	Schraube	VPE-Stckz.
0093AA00	12,2	1,0	11,0	9,2 x 9,2	7,0 x 7,0	0,5 - 2,0	0,8	2.500
0098AA00	12,2	1,0	11,0	9,2 x 9,2	7,0 x 7,0	0,5 - 2,0	0,8	2.500
0101AA00	15,0	1,2	18,0	12,2 x 12,2	9,5 x 9,5	0,5 - 2,0	8 -10 P	2.500
3515AA00	12,8	0,8	11,5	11,0 x 11,0	8,0 x 8,0	0,7 - 2,0	0,9	2.500