

# KABELHALTER SELBSTKLEBEND / SCHRAUBBAR

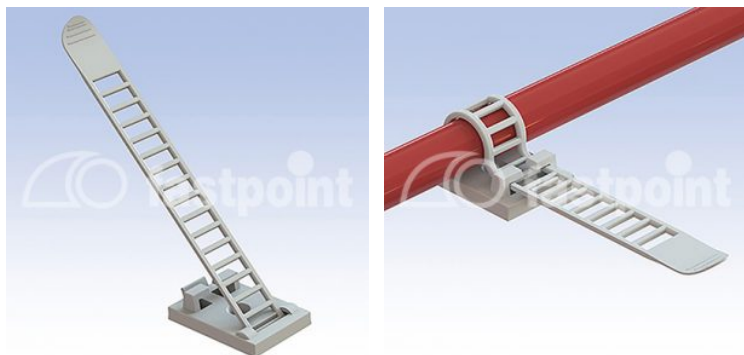

## Technische Beschreibung

**Material:** PA 6.6

**Entflammbarkeit:** V2 (UL 94)

**Temperaturbereich:**

- **PA 6.6:** -35° ~ +85°C

- **3M Klebeband:** Geschlossener PE Schaum, Klebstoff - Acrylat (-20°C ~ +80°C)

**Farbe:** Natur

Alle Maße in mm

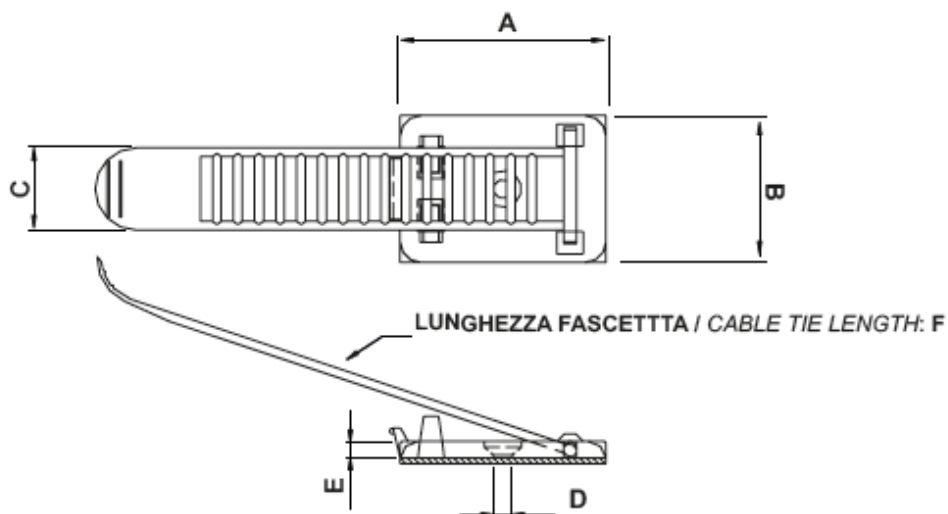

Artikel	A	B	C	D	E	F	VPE-Stckz.
6061AA00AS	30,2	21,0	12,0	3,5	2,5	91,0	100
6519AA00AS	25,4	18,1	8,0	3,5	2,5	64,2	200
6520AA00AS	25,4	18,1	8,0	3,5	2,5	85,0	200

Artikel	A	B	C	D	E	F	VPE-Stckz.
6521AA00AS	35,0	25,0	14,0	3,2	2,8	88,3	200
6522AA00AS	35,0	25,0	14,0	3,2	2,8	127,0	100
6523AA00AS	30,0	21,0	12,0	3,7	2,5	117,0	100